

CARATTERISTICHE TECNICHE TECHNICAL FEATURES

Principali caratteristiche:

- Ingombro ridotto
- Accessibilità
- Dosatore apribile ed estraibile
- Pannello comandi intuitivo
- Modularità e ampia possibilità di personalizzazione
- Movimenti con servomotori

Accessori:

Macinatore
Applicatore filtro intermedio
Saldatura ad ultrasuoni
Marcatore
Confezionamento singolo
Confezionamento multipack
Astucciatrice
Controllo qualità con telecamere
Controllo peso

PRODUZIONE:	240 CAPSULE/MIN
POTENZA INSTALLATA:	20KW
PESO MACCHINA:	2000 Kg
PRESSIONE DI LAVORO:	> 6 bar
CONSUMO PNEUMATICO:	700 NL/MIN
PRECISIONE:	+/- 0,2g

Main features:

- Small footprint
- Accessibility
- Easy-opening, removable dosing unit
- User-friendly HMI
- Modularity and wide range of customization
- Servo motion control

Accessories:

Grinder
Intermediate filter applicator
Ultrasonicsealing device
Printer
HFFS for single capsule packaging
VFFS for multi-capsules packaging
Cartoning machine
Vision System
Check weigher

CAPACITY:	240 CAPSULE/MIN
INSTALLED POWER:	20KW
MACHINE WEIGHT:	2000 Kg
WORKING PRESSURE:	> 6 bar
COMPRESSED AIR CONSUMPTION:	700 NL/MIN
ACCURACY:	+/- 0,2g



FLEXYCAPS - X4

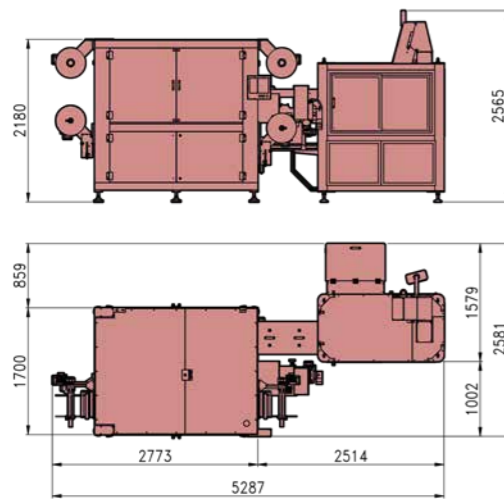

Con fine linea - With end of line

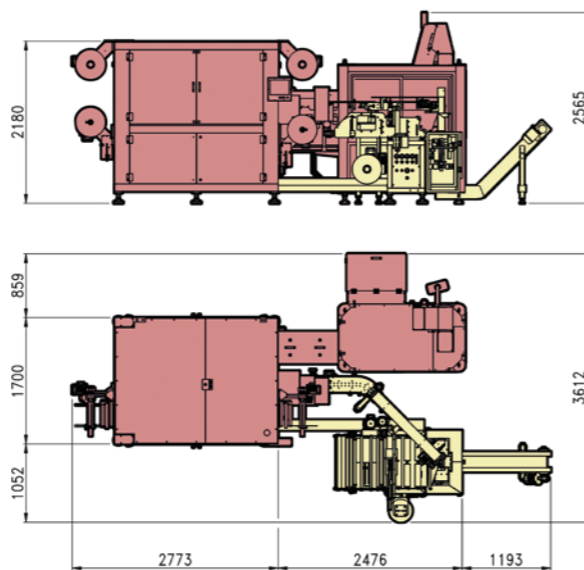

FLEXYCAPS - X4

LINEA DI RIEMPIMENTO CAPSULE
CAPSULES FILLING MACHINE

Profitech S.r.l. | Packaging Machines
Via E.Mattei, 154 | 29010 - Alseno (PC) - ITALY
Tel: +39 0523 945044 | Fax +39 0523 1740043
Mail: info@profitech.it | www.profittech.it

Profitech
Packaging Machines

FLEXYCAPS - X4

FLEXYCAPS-4 nasce per soddisfare le esigenze di confezionamento di capsule con caffè e prodotti solubili.

Le caratteristiche principali sono la compattezza e l'accessibilità.

La giostra di riempimento comandata da servomotore torque garantisce precisione e flessibilità, il dosatore a coclea con tramoggia apribile ed estraibile si distingue per precisione e praticità.

La doppia saldatura del coperchio superiore assicura la perfetta ermeticità, il sistema di flussaggio di gas inerte protegge il prodotto durante il confezionamento.

FLEXYCAPS-4 was developed to meet the needs of packaging capsules with coffee and solubles products.

Its main features are compactness and accessibility.

The filling carousel controlled by torque servomotor guarantees precision and flexibility, the dosing unit with easy-opening, removable hopper stands out for its accuracy and practicality.

The double sealing of the top lid ensures absolute tightness, the inert gas flux system protects the product throughout the packaging process.



A. Introduzione capsule nella giostra di riempimento e dosaggio/riempimento capsule.

Insertion of capsules into the filling carousel and dosing/filling of capsules.

B. Taglio/saldatura del filtro intermedio e del coperchio superiore. Trascinamento del film intermedio e del coperchio superiore. Zona di flussaggio gas inerte.

Punching/sealing of intermediate filter and top lid. Pulling of intermediate film and top lid. Inert gas flux zone.

C. Estrazione capsule dalla giostra di riempimento e posizionamento su trasportatore a cinghie. Ribaditura della saldatura del coperchio superiore.

Second sealing of the top lid. Exit pick and place and positioning of capsules onto outfeed belt conveyor.

D. Scarto delle capsule non conformi allo standard e uscita per abbinamento al fine linea. Dispositivo di riavvolgimento dello sfrido.

Discard of not conforming capsules and exit for end-of-line matching. Scrap rewinding device.

